

Installation Instructions

1. LOCATING AND SETTING UP:

Care should be taken when moving press into position. The table sections are not strong enough to be used for lifting or pushing the press. Once positioned correctly, i.e. level, with clearance to walk all around and with illumination from either side, the press can be bolted down. Four holes are provided in the press base for this purpose. Carefully remove the wooden block holding the head closed and then allow head to open. Remove the paper wrapping from the buck.

2. STEAM SUPPLY:

It is extremely important the steam supplied to the press is dry. To do this, the boiler must be controlled correctly! For the best results a minimum steam pressure of 400kPa (60lb./in.) is recommended with a maximum of 550kPa (80lb./in.). Where the steam supply is found to be in excess of 550 kPa (80lb./in.) a pressure-reducing valve must be installed. To reduce condensate and heat losses it is recommended that all steam feed piping be covered.

3. STEAM CONNECTION:

The 1/2" inlet pipe, on the right side of the press, should be connected to the steam supply line with a globe valve and union near this connection point. Be sure connection to the steam main is taken off the top of the main line. Pitch all supply upwards to the press; this allows condensation to drain back to the boiler.

4. CONDENSATE CONNECTION:

The 1/2" condensate outlet pipe on the left side of the press should be connected to a suitable main, to return the condensate to the boiler feed tank. Before entering this main, the following should be fitted in accordance with their manufacturer's recommendation nearest the press:

- "Y" strainer
- Bucket or Thermodynamic-type steam trap
- Sight glass
- Check valve

For models fitted with larger bucks and heads (e.g. Models TTL1 or U42) a short, 3/8" by pass line should be fitted to allow the condensate to by-pass the steam trap when starting up. This will speed up press heat-up time.

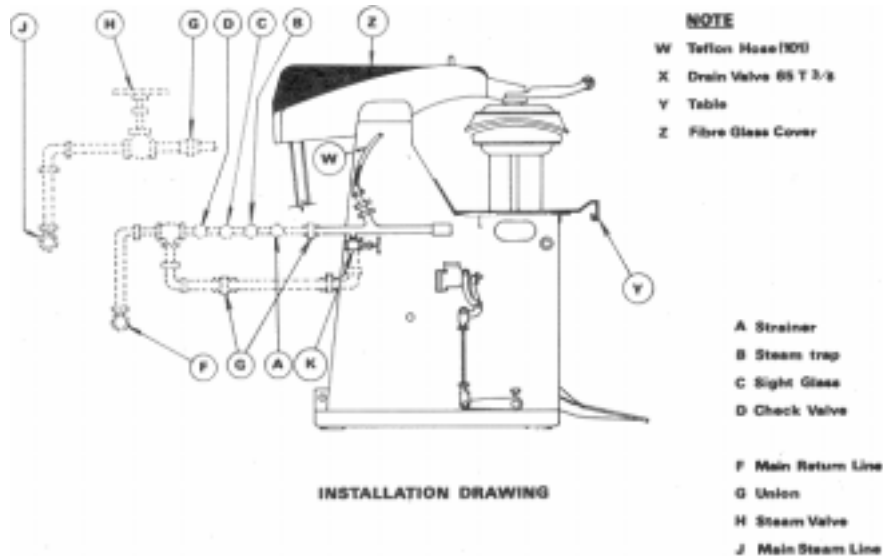

SEICKEL & SONS INC.

MANUFACTURERS & REBUILDERS OF STEAM PRESSING EQUIPMENT

360 ELIZABETH AVE., NEWARK, NJ 07112 TEL. 973-242-1948 FAX 973-733-4956
315 WEST 36TH ST., SUITE 504, NY, NY 10018 TEL. 212-290-2120 FAX 212-290-2140
TOLL FREE IN U.S. 1-800-338-5044

WEB WWW.SEICKEL.COM

SALES@SEICKEL.COM

